

# Vertikale ballepresser

## B-serien

# Ballepresse B30 Wide SD



### Papresse for veldig store bokser

Med et ekstra stort kammer på mer enn 1,5 m, kan denne maskinen håndtere de største boksene.

### Høyt komprimeringsforhold

Presset på ballen blir opprettholdt mens du knyter den. Dette gir deg en svært kompakt og stabil papp- eller plastball.

### Høydepunkter

- Ekstra stort kammer (>1,5 m)
- Egner seg selv for stor bokser
- Bruk plast- eller metalltråd
- Varsel når kammeret er fullt
- Utballing skjer automatisk
- Produserer store pappballer på minst 400 kg
- Pulverlakkering gir en slitesterk overflate i mange farger

## Tilleggsutstyr



Kontroller hvem som kan betjene ballepressen med en automatisk lås.



Få tilgang til ballepressene dine ved hjelp av vårt digitale overvåkingssystem, BRA-IN.



Bestill emballasjepressen i en farge du ønsker.

# Produktdetaljer

## Ballepresse B30 Wide SD



Hviske

30 dB



Kjøleskap

50 dB



B30 Wide SD

62-64 dB



Andre ballepresser

75 dB

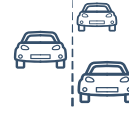

Biler på motorvei

100 dB



Turbojet motor

160 dB

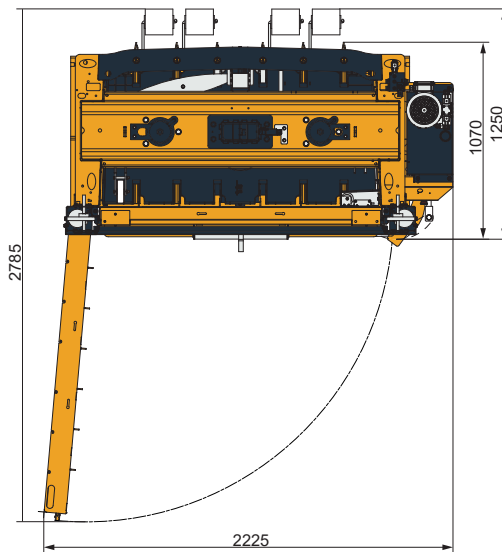
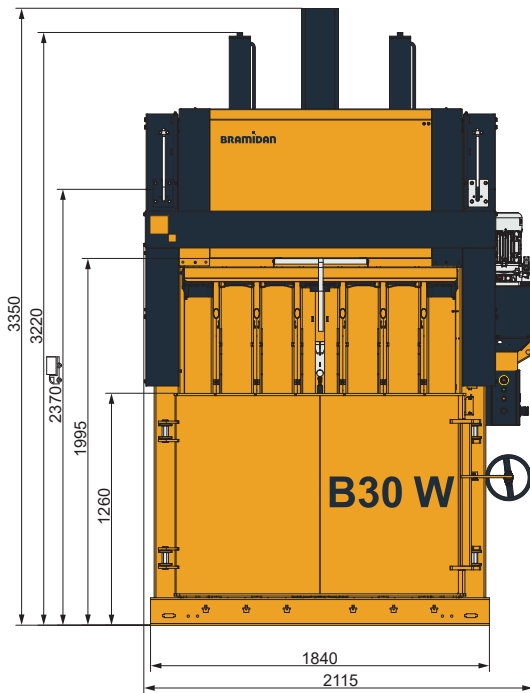

### Tekniske spesifikasjoner

Ballestørrelse BxDxH (mm)	1550 x 800 x 1100
Innkast åpning BxH	1525 x 560
Strømforsyning	3x400V 50Hz 16A / 3x230V 50Hz 32A
Motor (kW)	4.0
Syklustid gj.s. (sek)	43
Dimensjoner BxDxH (mm)	2080 x 1255 x 3350
Vekt (kg)	1820
Slaglengde (mm)	1000
Antall bånd	6
Type bånd	Fiberbånd / Ståltråd
Full balle varselampe	Ja
Balleutømning	Automatisk



**Balle vekt**  
 Papp (kg) 400-500  
 Plastfolie (kg) 400-600



**Pressekraft** 30 t



**Støynivå** 62-64 dB



**Avfallstype**  
 Papp, plastfolie, papir.

**BRAMIDAN**  
 bramidanpresto.no

Bramidan & Presto AS  
 Narverødveien 40  
 3113 Tønsberg  
 Tel. 481 16 600  
 post@bramidanpresto.no