

Vertikale ballepresser

B-serien



Ballepresse B50 XL SD

Effektiv og rask avfallshåndtering

Ideell for store mengder materialer. På grunn av skyvedøren på 1.82 meter og det dype kammeret på 1.1 meter, så trenger man ikke å brette sammen bokser før de fylles på.

Optimalisert for lasting på lastebil

De komprimerte ballene er optimalisert for transport fordi de kan bli stablet to og to istedenfor tre og tre.

Høydepunkter

- Ekstra stort kammer
- 8 tråder for en mer stabil ball
- Standard med skyvedører som åpnes automatisk
- Baller som er optimale for transport
- Komprimerte baller måler 1825 x 1100 x 1200-1300 mm
- Stable ballene 2 og 2, istedenfor 3 for optimal lasting på lastebil
- Pulverlakkering gir en slitesterk overflate i mange farger

Tilleggsutstyr



Ballepressen er tilgjengelig i andre RAL-farger.



Få oversikt over ballepressene dine med vårt digitale overvåkingssystem, BRA-IN.



For å binde sammen ballene som er ferdige kan du enten bruke fiberbånd eller ståltråd.

Produktdetaljer

Ballepresse B50 XL SD



Hviske

30 dB



Kjøleskap

50 dB



B50 XL SD

62-64 dB



Andre ballepresser

75 dB

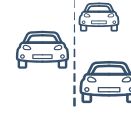

Biler på motorvei

100 dB



Turbojet motor

160 dB

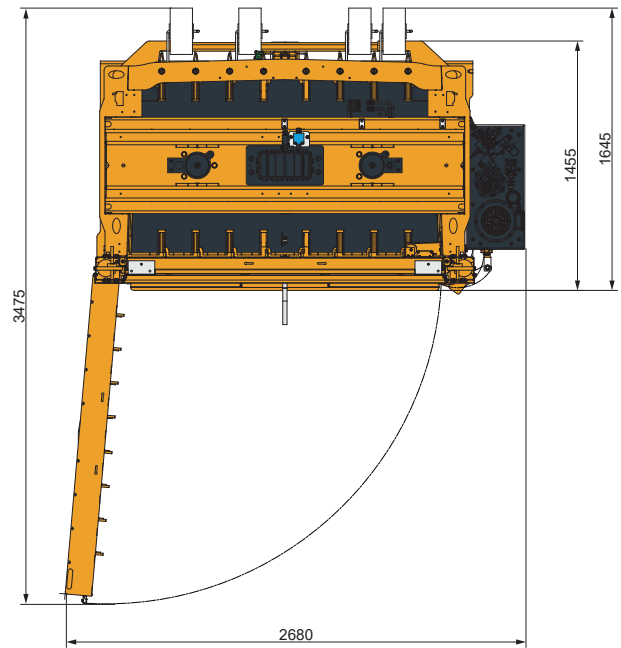
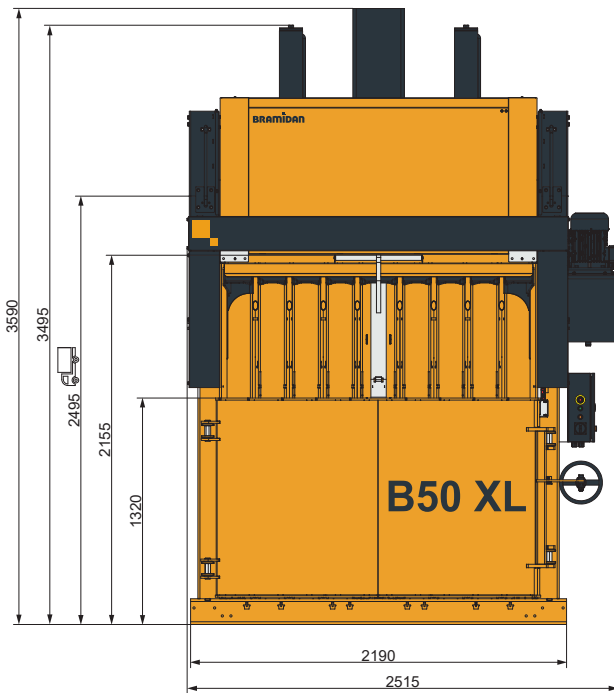

Tekniske spesifikasjoner

Ballestørrelse BxDxH (mm)	1850 x 1100 x 1200-1300
Innkast åpning BxH	1825 x 670
Strømforsyning	3x400V 50Hz 16A / 3x230V 50Hz 32A
Motor (kW)	5.5
Syklustid gj.s. (sek)	26
Dimensjoner BxDxH (mm)	2495 x 1660 x 3590 / 2540
Vekt (kg)	3250
Slaglengde (mm)	1100
Antall bånd	8
Type bånd	Fiberbånd / Ståltråd
Full balle varselampe	Ja
Balleutømning	Automatisk



Balle vekt
Papp (kg) 650-800
Plastfolie (kg) 650-800



Pressekraft 50 t



Støynivå 62-64 dB



Avfallstype
Papp, plastfolie, papir.

BRAMIDAN
bramidanpresto.no

Bramidan & Presto AS
Narverødveien 40
3113 Tønsberg
Tel. 481 16 600
post@bramidanpresto.no