

# Vertikale ballepresser

## B-serien



## Ballepresse B50

### For optimal transportlogistikk

B50 modellen tilbyr effektiv komprimering til tett baller med ideelle dimensjoner for optimal transportlogistikk.

### Perfekt ballestørrelse

Ballene måler 1200 mm x 800 mm x 1100 mm og passer på en standard EUR pall.

### Høydepunkter

- Maskinens design og demonterbare sylindere gir lav vekt under transport
- Bruker standard 16A uttak
- Lavt støynivå
- Høy kompresjonsgrad
- Produserer store baller (minimum 400 kg papp)
- Pulverlakkering gir en slitesterk overflate i mange farger

## Tilleggsutstyr



En skyvedør bli stående åpen for enkel påfylling.

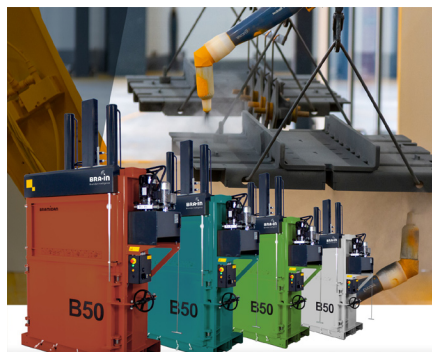

Ballepressen er tilgjengelig i andre RAL-farger.



Få oversikt over ballepressene dine med vårt digitale overvåkningsystem, BRA-IN.

# Produktdetaljer

## Ballepresse B50



Hviske

30 dB



Kjøleskap

50 dB



B50

62-64 dB



Andre ballepresser

75 dB

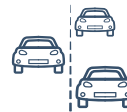

Biler på motorvei

100 dB



Turbojet motor

160 dB

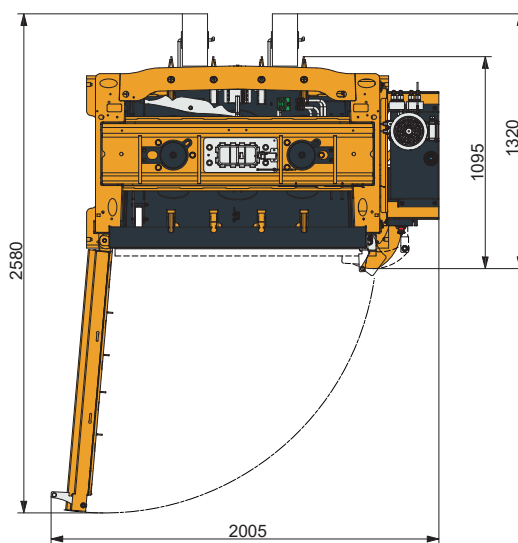
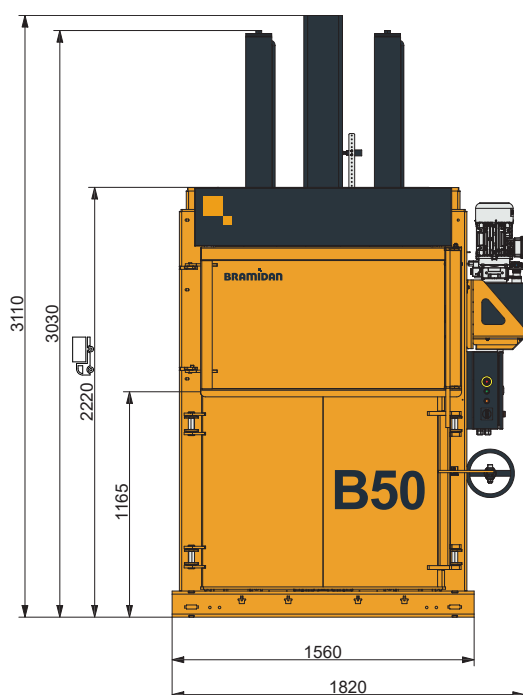

### Tekniske spesifikasjoner

Ballestørrelse BxDxH (mm)	1200 x 800 x 1100
Innkast åpning BxH	1200 x 565
Strømforsyning	3x400V 50Hz 16A / 3x230V 50Hz 32A
Motor (kW)	4.0
Syklustid gj.s. (sek)	55 / 26
Dimensjoner BxDxH (mm)	1820 x 1320 x 3110
Vekt (kg)	1755
Slaglengde (mm)	900
Antall bånd	4
Type bånd	Fiberbånd / Ståltråd
Full balle varselampe	Ja
Balleutømning	Automatisk



**Balle vekt**  
Papp (kg) 400-500  
Plastfolie (kg) 450-550



**Pressekraft** 50 t



**Støynivå** 62-64 dB



**Avfallstype**  
Papp, plastfolie, papir.

**BRAMIDAN**  
bramidanpresto.no

Bramidan & Presto AS  
Narverødveien 40  
3113 Tønsberg  
Tel. 481 16 600  
post@bramidanpresto.no