

# Vertikale ballepresser

## B-serien



## Ballepresse B4

En kompakt og kraftfull emballasjepresse  
B4'en er en kompakt pappresse med et lite fotavtrykk samt lav høyde. Den har også en stor pressekraft

Optimalt arbeidsmiljø  
Den ferdige ballen tømmes fra maskinen ved bruk av en sikker to-hånds operasjon.

### Høydepunkter

- Oversiktlig kontrollpanel
- Automatisk utballing
- Automatisk full-balle indikator
- Ekstremt lavt støynivå (<60 dB)
- Lav bredde (940 mm) og høyde (<2 metres)
- En ferdig ball måler kun 70 x 50 x 35-65 cm
- Maskinen styres fra fronten, noe som gjør den egnet til trange plasseringer
- En-fase strømforsyning
- Pulverlakkering gir en slitesterk overflate i mange farger

### Tilleggsutstyr



Kontroller hvem som betjener emballasjepressen med digital autolås.



Du kan velge andre RAL-farger for ballepressen.



Få tilgang til ballepressen på nett med vårt overvåkingssystem, BRA-IN.

# Produkt detaljer

## Ballepresse B4



Hviske

30 dB



Kjøleskap

50 dB



B4

57-60 dB



Andre ballepresser

75 dB

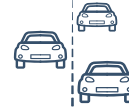

Biler på motorvei

100 dB



Turbojet motor

160 dB

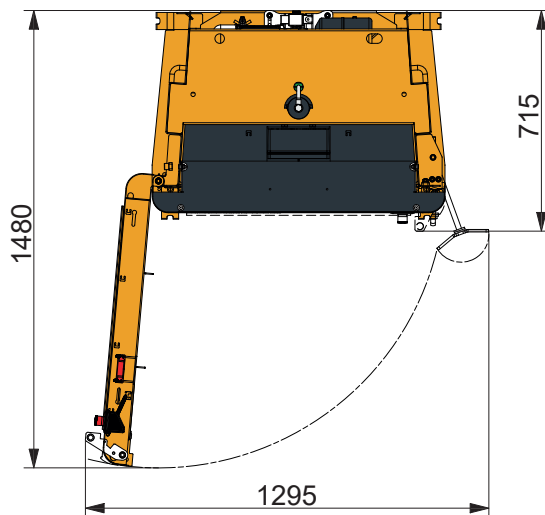
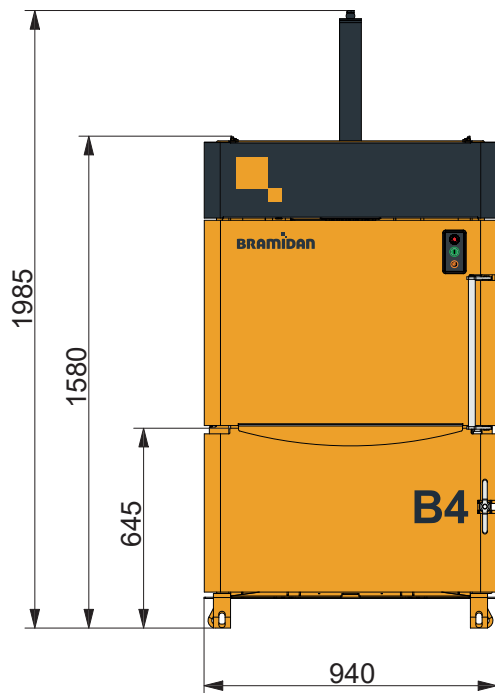

### Tekniske spesifikasjoner

Ballestørrelse BxDxH (mm)	770 x 500 x 600
Innkast åpning BxH	770 x 460
Strømforsyning	1x230V 50Hz 10A
Motor (kW)	1.5
Syklustid gj.s. (sek)	28
Dimensjoner BxDxH (mm)	940 x 715 x 1985
Vekt (kg)	300
Slaglengde (mm)	650
Antall bånd	2
Type bånd	Fiberbånd
Full balle varselampe	Ja
Balleutømning	Automatisk



Balle vekt  
Papp (kg) 40-60  
Plastfolie (kg) 50-70



Pressekraft 4 t



Støynivå 57-60 dB



Avfallstype  
Papp, plastfolie, papir.

**BRAMIDAN**  
bramidanpresto.no

Bramidan & Presto AS  
Narverødveien 40  
3113 Tønsberg  
Tel. 481 16 600  
post@bramidanpresto.no